

### Features

- 32”(813) x 24”(610) x 37.3”(947.4)
- Sturdy, double door cabinet with drawer provides plenty of storage and is constructed of 304 stainless steel.
- Doors feature soft close hinges.
- 32" countertop made from 19 gauge 304 stainless steel.
- One internal shelf board included in each cabinet base unit.
- Adjustable feet included for leveling cabinet.
- Two locking swivel casters and two fixed casters.
- Rain-resistant cover is included for outdoor storage.
- UV-resistant. Clean, modern surfaces will not tarnish.
- Stainless steel surfaces resists stains and are easy to clean.

### Warranty

- Lifetime Limited Residential Warranty



### Specified Model

Model	SMOBC3224
Overall Dimensions	W32" x D24" x H37.3" L813 x W610 x D947.4
Shipping Weight	92 lbs.
Material	0.6mm/304 stainless steel – Cabinet 19 GA./304 stainless steel – Countertop

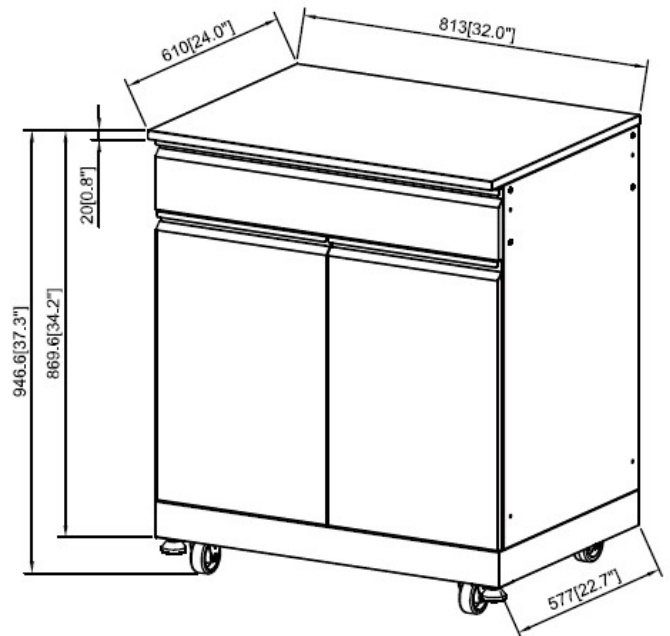

**Codes/Standards**  
ASME A112.19.3/CSA B45.4

**Notes:**  
Install this product according to the installation instructions.