

## Features

- 64”(1625) x 24”(610) x 37.3”(947.4)
- Two sturdy, double door cabinets with drawers provides plenty of storage and is constructed of 304 stainless steel.
- Doors feature soft close hinges.
- 64” countertop made from 19 gauge 304 stainless steel.
- Single unit countertop fits over two single cabinet base units.
- One internal shelf board included in each cabinet base unit.
- Adjustable feet included for leveling cabinet.
- Four locking swivel casters and four fixed casters.
- UV-resistant. Clean, modern surfaces will not tarnish.
- Stainless steel surfaces resists stains and are easy to clean.

## Warranty

- Lifetime Limited Residential Warranty

## Specified Model

Model	SMOBC6424
Overall Dimensions	W64” x D24” x H37.3” L1625 x W610 x D947.4
Shipping Weight	154 lbs.
Material	0.6mm/304 stainless steel – Cabinet 19 GA./304 stainless steel – Countertop

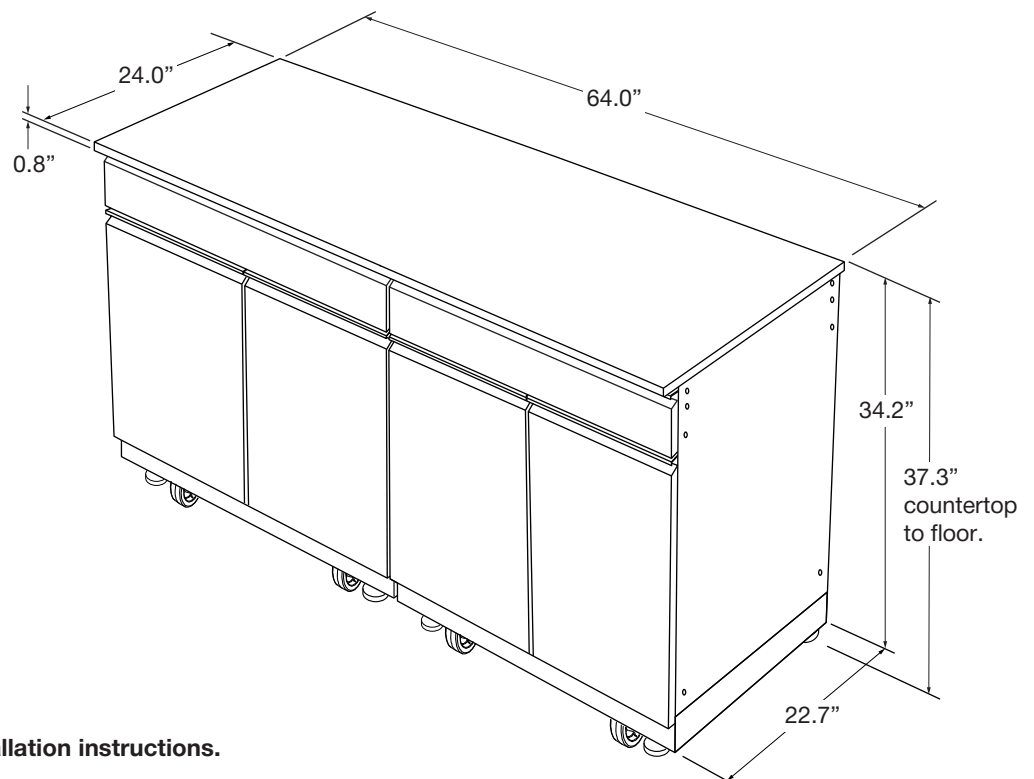

## Codes/Standards

ASME A112.19.3/CSA B45.4

## Notes:

Install this product according to the installation instructions.