

Features

- 67"(1702) x 24"(610) x 37.3"(947.4)
- Sturdy, double door cabinet provides plenty of storage and is constructed of 304 stainless steel.
- Doors feature soft close hinges.
- 32" countertop made from 19 gauge 304 stainless steel.
- Two stainless steel folding shelves, one on each side of the cabinet, fold down when not in use. 20-1/16" towel rod attached to outside edge of each shelf.
- One internal shelf board included in each cabinet base unit.
- Adjustable feet included for leveling cabinet.
- Two locking swivel casters and two fixed casters.
- UV-resistant. Clean, modern surfaces will not tarnish.
- Stainless steel surfaces resists stains and are easy to clean.

Warranty

- Lifetime Limited Residential Warranty

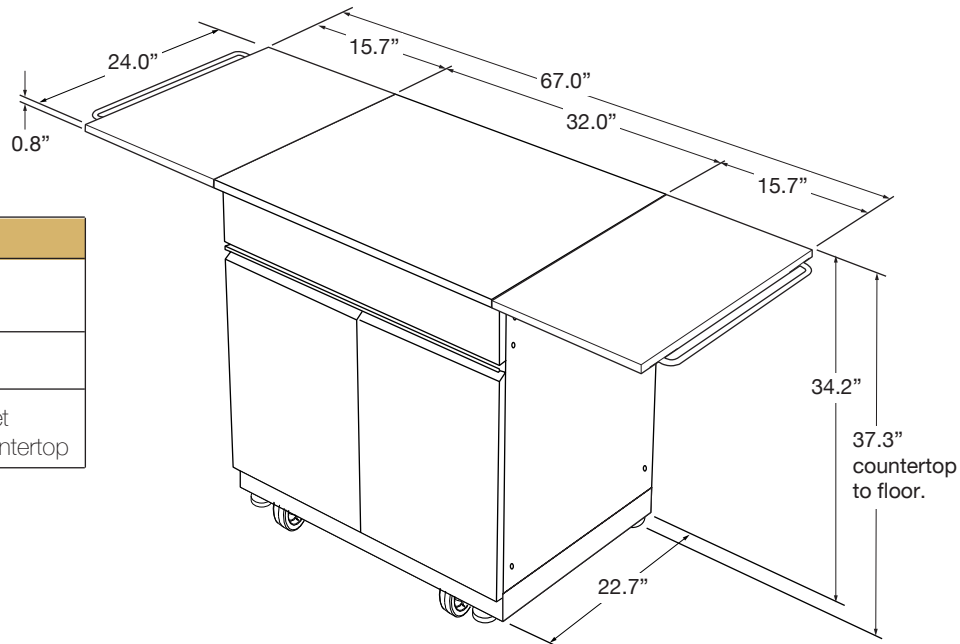

Specified Model

Model	SMOUCS3224
Overall Dimensions	W67" x D24" x H37.3" L1702 x W610 x D947.4
Shipping Weight	116 lbs.
Material	0.6mm/304 stainless steel – Cabinet 19 GA./304 stainless steel – Countertop

Codes/Standards

ASME A112.19.3/CSA B45.4

Notes:

Install this product according to the installation instructions.